

Soluzioni Industriali Ergonomiche



Soluzioni Industriali Ergonomiche

ERGONOMIA

ERGON = LAVORO

NOMOS = LEGGE

L'ergonomia è una materia nata nel 1949 in Inghilterra.

L'obiettivo che si propone è di tutelare la sicurezza e la salute e di promuovere il benessere delle persone sul lavoro.

Soluzioni Industriali Ergonomiche

Prima dell'ergonomia

L'uomo si adatta alla macchina (si cercano le persone adatte a svolgere un determinato compito)

Dopo l'ergonomia

La macchina si adatta all'uomo (si fa in modo che tutti, utilizzando determinati dispositivi, possano svolgere qualsiasi mansione)

Soluzioni Industriali Ergonomiche

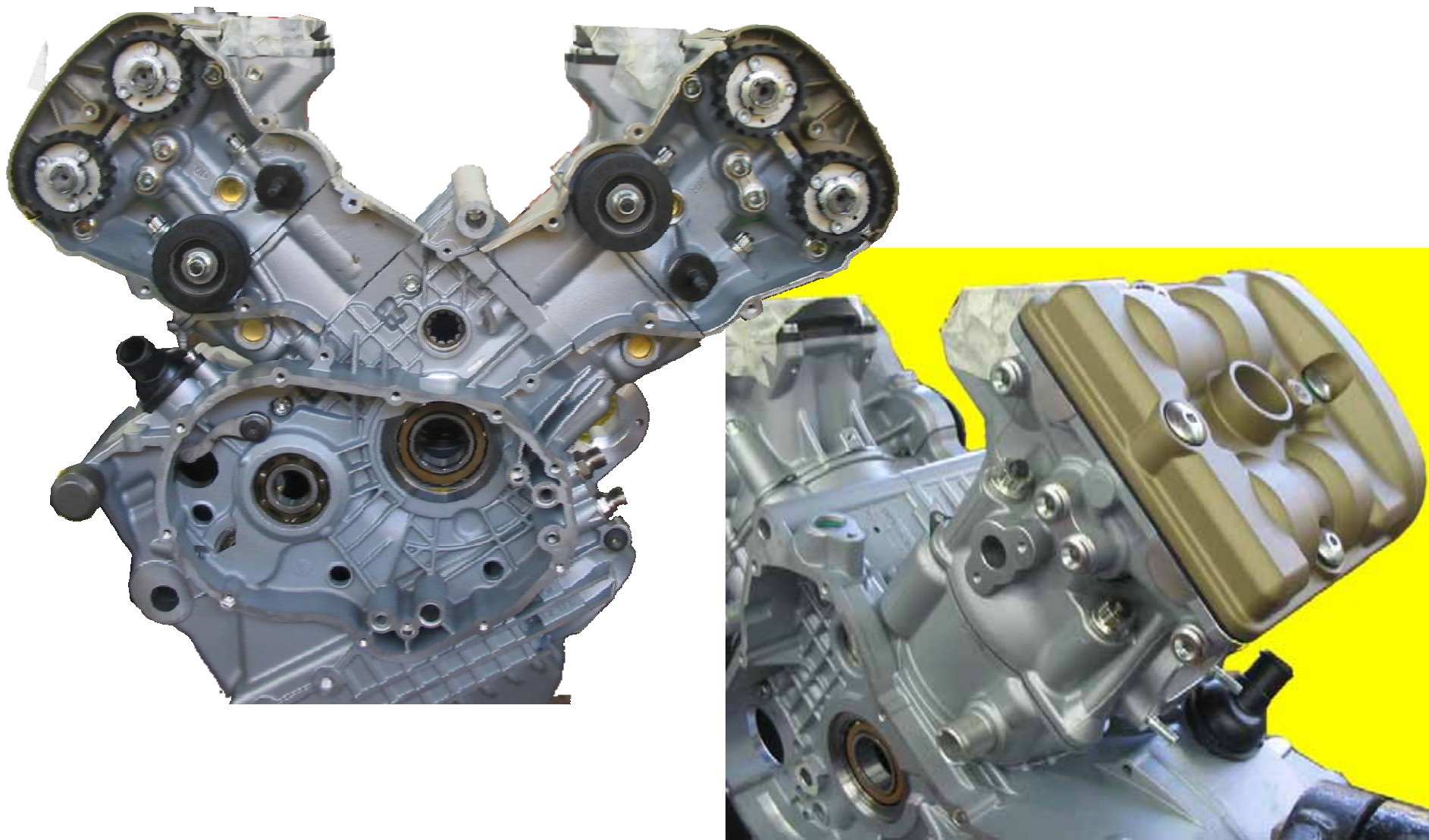

Soluzioni Industriali Ergonomiche



Soluzioni Industriali Ergonomiche

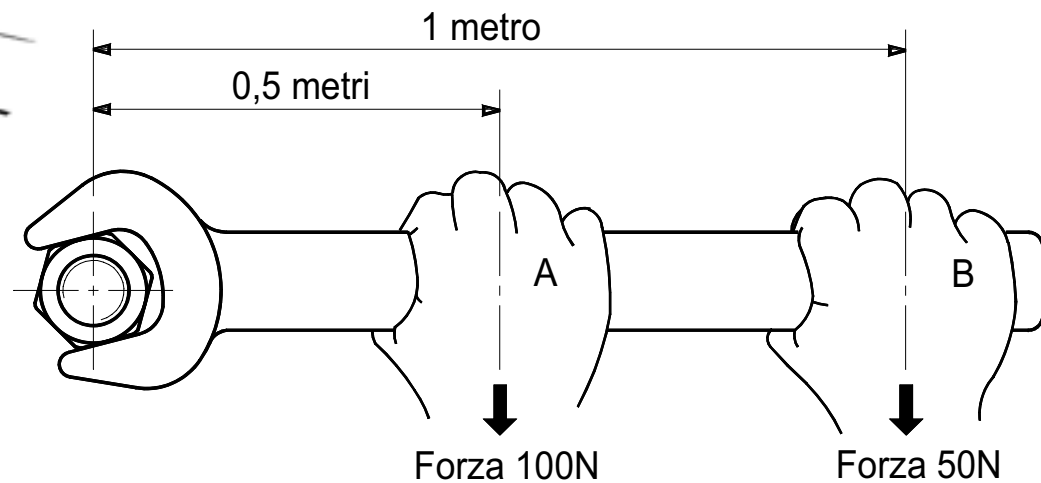
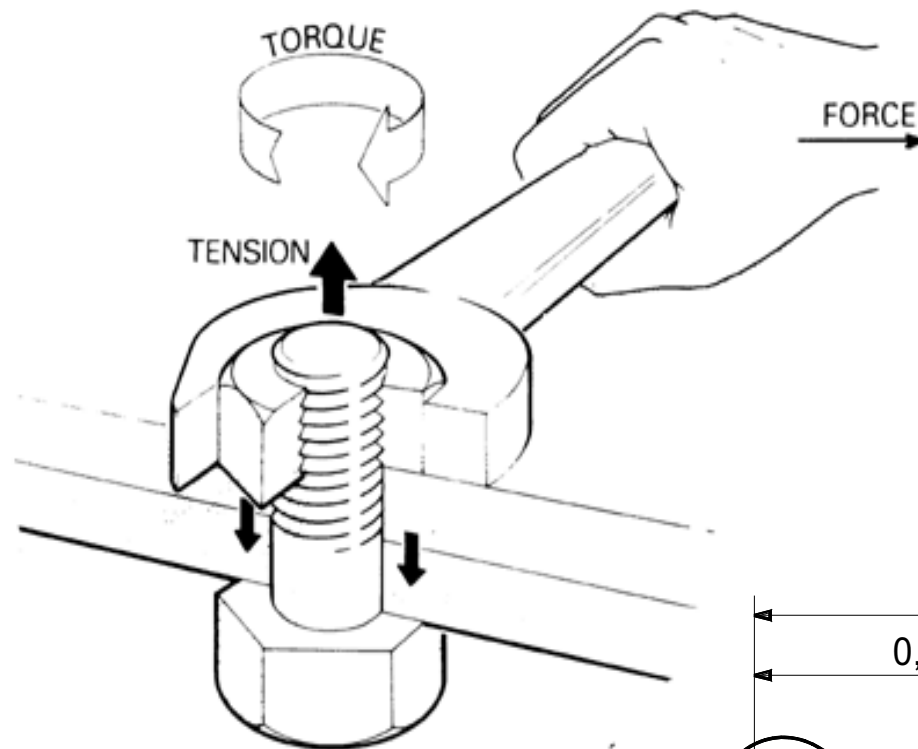

Soluzioni Industriali Ergonomiche

- ▶ nelle isole di montaggio
- ▶ sopra un banco di lavoro
- ▶ lungo una linea di assemblaggio

UN SERVOMEZZO PUO' ESSERE

sospeso



bilanciato

reazionato



Soluzioni Industriali Ergonomiche



SISTEMI DI BILANCIAMENTO

MECCANICI:

a rullo cilindrico:

aumentando la corsa, si incrementa la forza di trazione

a rullo conico:

la forza di trazione è costante all'aumentare della corsa

ELETTRONICI:

sono dispositivi simili ai paranchi elettrici dove una cella di carico permette di controllare in ogni istante il carico applicato bilanciando perfettamente il peso

Soluzioni Industriali Ergonomiche

Caratteristiche fondamentali per un dispositivo di reazione e bilanciamento ergonomico:

- ▶ dimensionamento corretto
- ▶ leggerezza
- ▶ manovrabilità
- ▶ posizionamento corretto nell'area di lavoro

**un dispositivo di reazionamento
deve essere un aiuto,
non un problema**

Soluzioni Industriali Ergonomiche

ASSEMBLAGGIO DA BANCO



Soluzioni Industriali Ergonomiche

OPZIONI DI INSTALLAZIONE

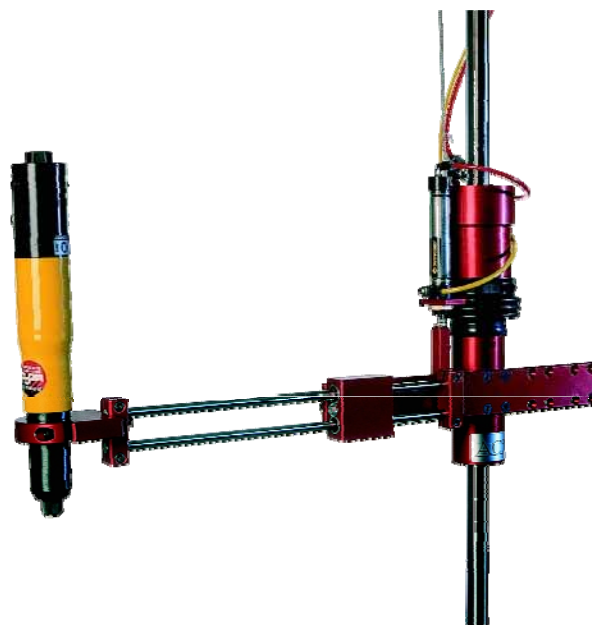
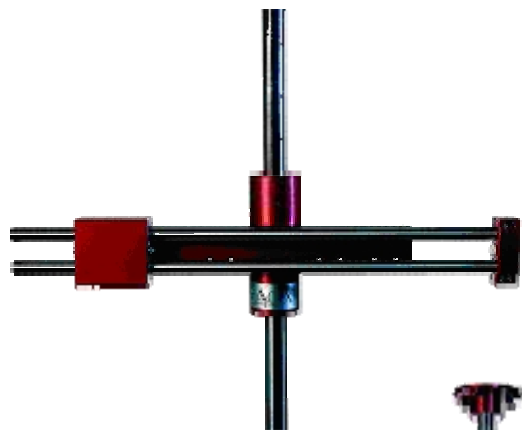

Soluzioni Industriali Ergonomiche



BA40
con multiplo 2 mandrini



Soluzioni Industriali Ergonomiche



Soluzioni Industriali Ergonomiche



Soluzioni Industriali Ergonomiche

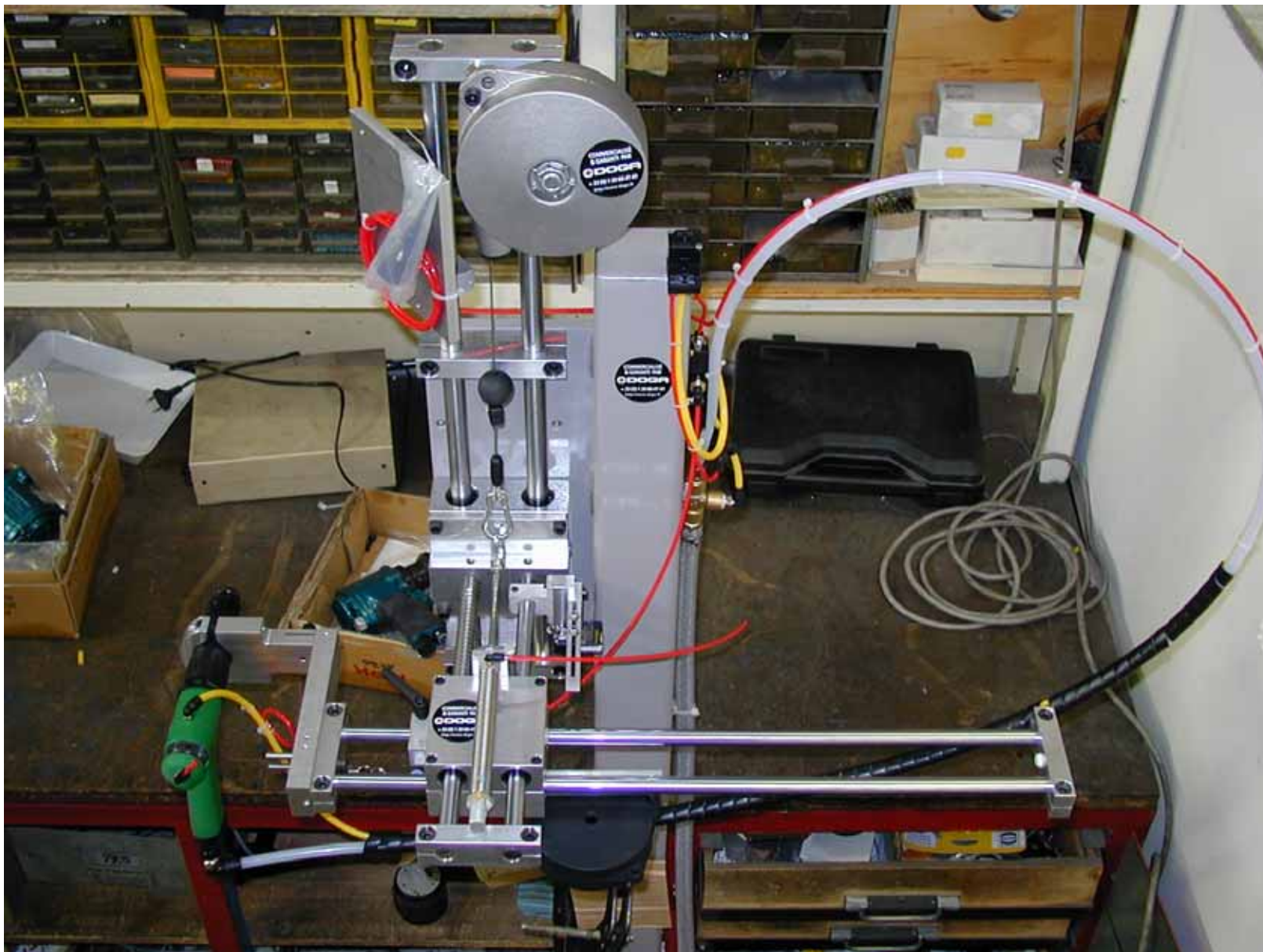

Soluzioni Industriali Ergonomiche

ASSEMBLAGGIO LUNGO LINEA

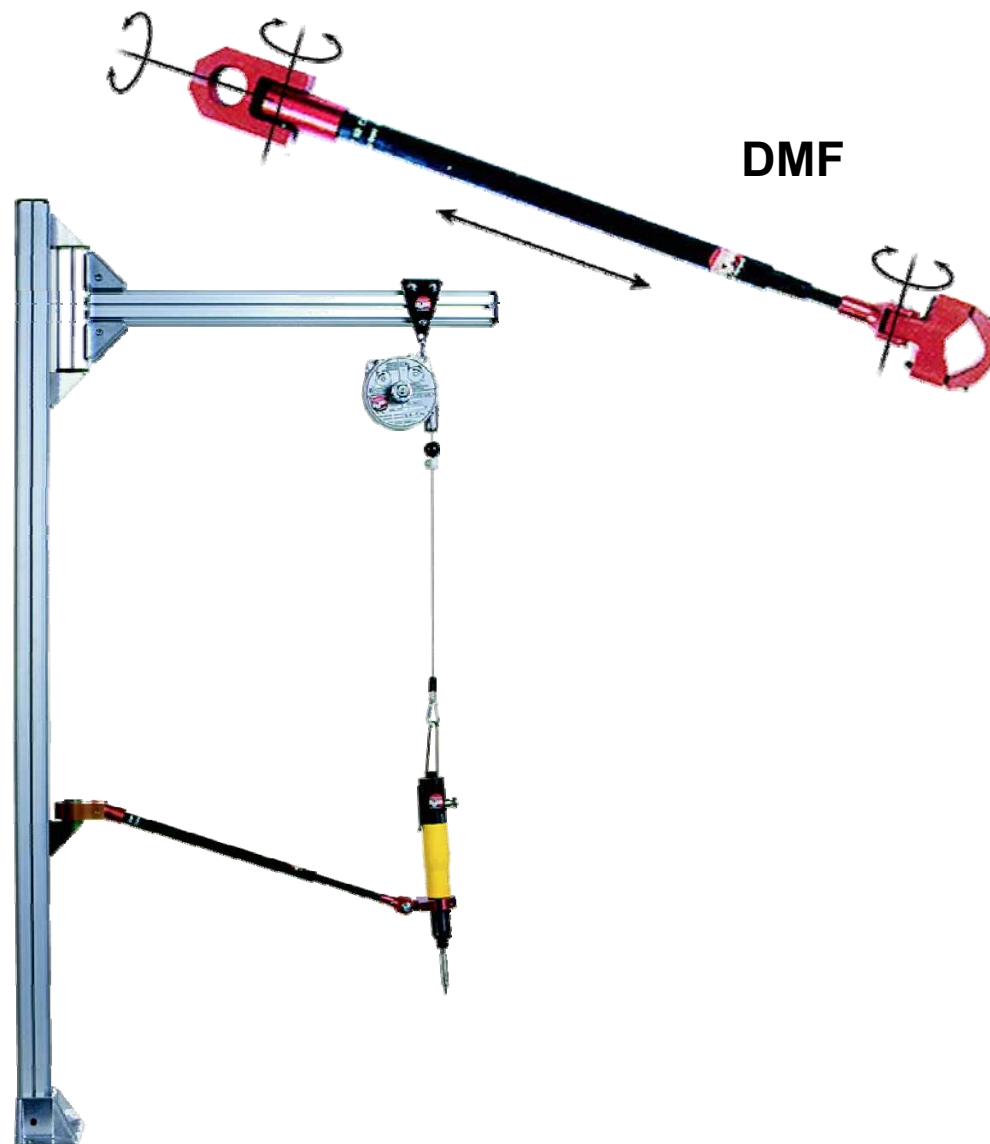

DMF

Soluzioni Industriali Ergonomiche



Soluzioni Industriali Ergonomiche

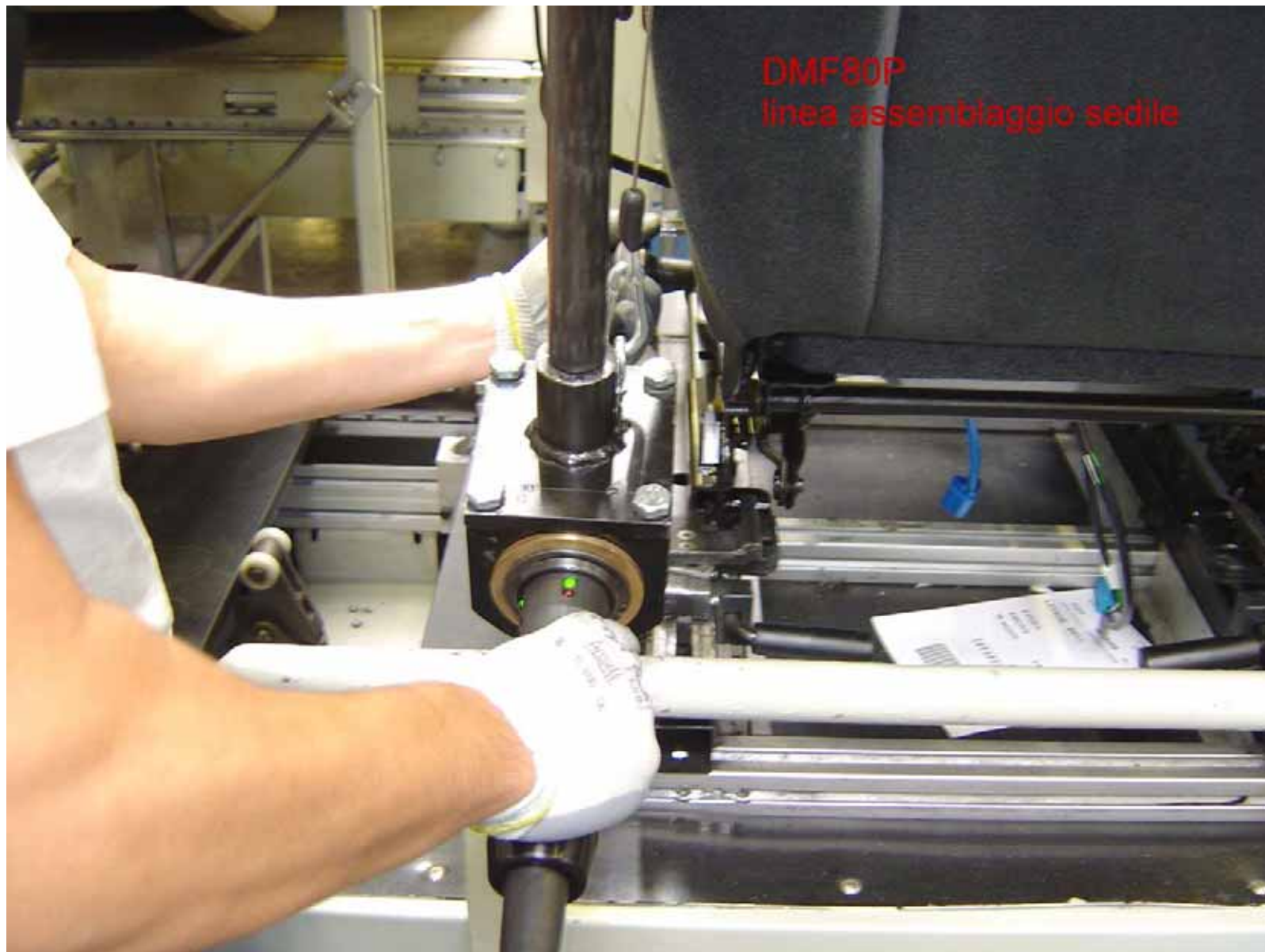

Soluzioni Industriali Ergonomiche



Soluzioni Industriali Ergonomiche



Soluzioni Industriali Ergonomiche

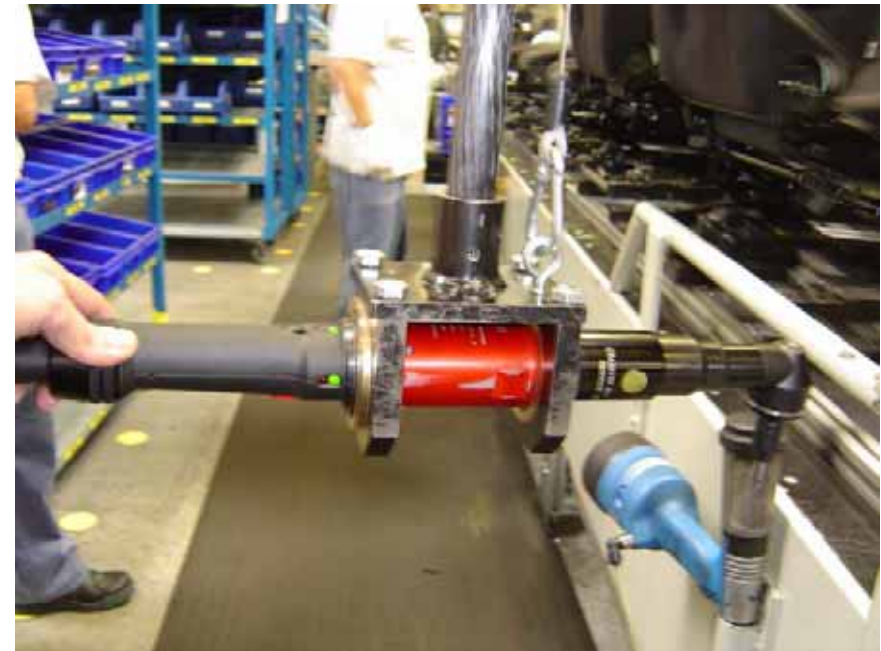

Soluzioni Industriali Ergonomiche



Soluzioni Industriali Ergonomiche



Soluzioni Industriali Ergonomiche



SLIDER



Soluzioni Industriali Ergonomiche



Soluzioni Industriali Ergonomiche



Soluzioni Industriali Ergonomiche



Soluzioni Industriali Ergonomiche



Soluzioni Industriali Ergonomiche



Soluzioni Industriali Ergonomiche

BRACCI PER ISOLE DI MONTAGGIO (reazionamenti fino a 1000 Nm)

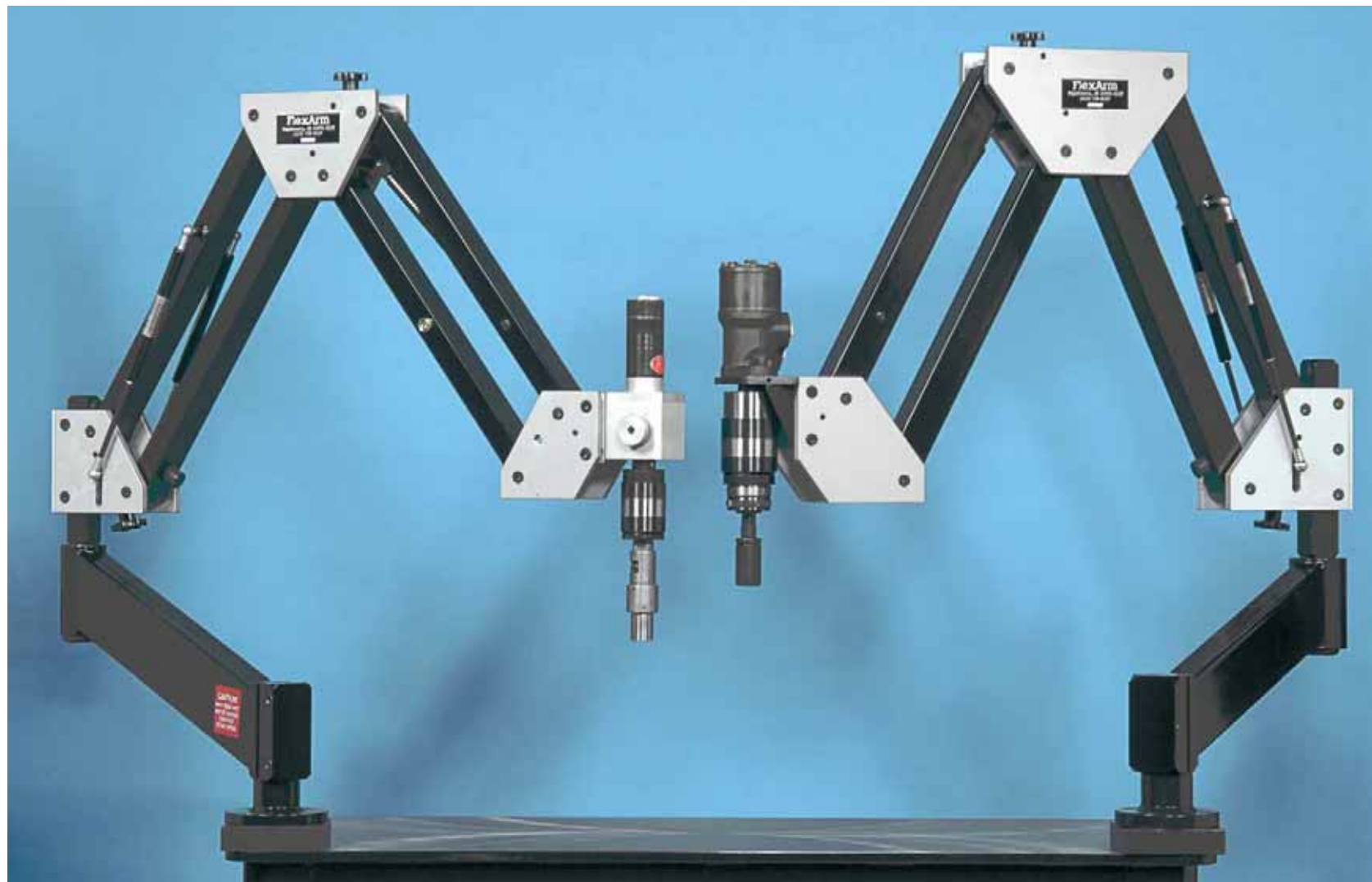

Soluzioni Industriali Ergonomiche



Soluzioni Industriali Ergonomiche



Soluzioni Industriali Ergonomiche

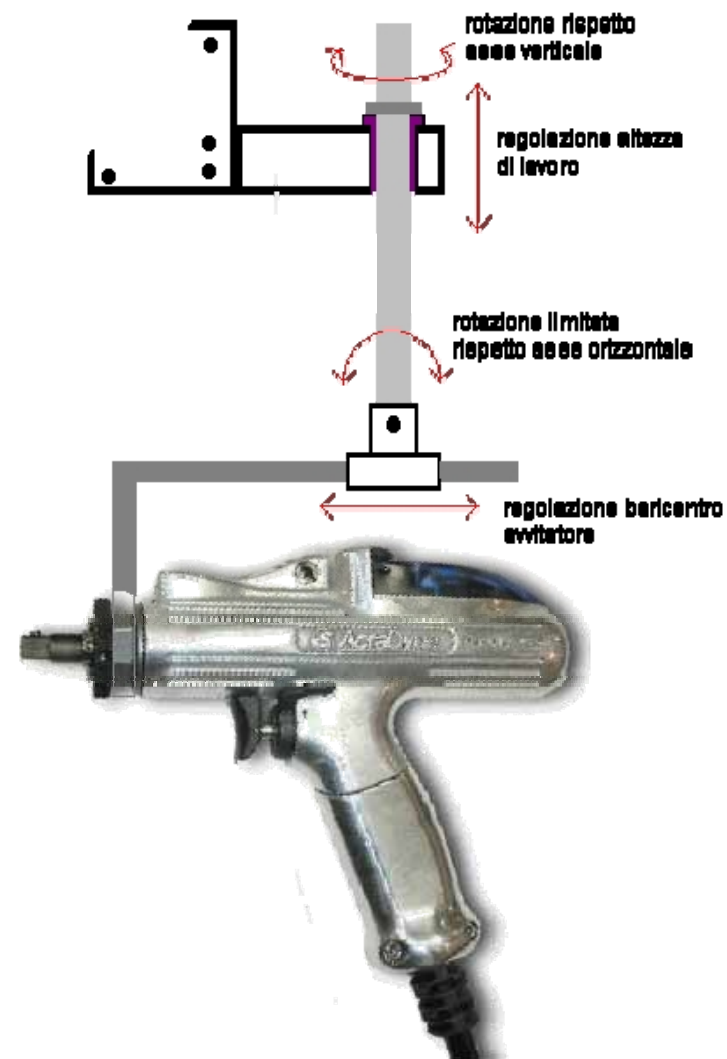

Soluzioni Industriali Ergonomiche



Soluzioni Industriali Ergonomiche



Soluzioni Industriali Ergonomiche



Soluzioni Industriali Ergonomiche



Soluzioni Industriali Ergonomiche

